

Design and Fabrication of Ash Brick Machine

Shivasheesh Kaushik, Dr. Anirudh Gupta

Abstract— In this present research project fly ash brick machine was manually manufactured on the basis of basic need which was evaluated after considering present problem statement which generally occurs in constructional areas through theoretical literature with practical survey and with several and different points which focus attention toward such type of special purpose manufacturing such as production rate, effective solution for positive utilization of fly ash which produces in power plant day by day, solution for such points is fly ash bricks which are using in constructional areas such as buildings, roads etc and also, analyzing of varying parameters such as size of bricks, material for bricks, mould size, die size play an important role as a deciding factor for fabrication of such multi purpose fly ash brick machine which is usefull in producing wide and verctile range of fly ash bricks with varying range of shapes . The "Fly Ash Brick Making Machine" compresses ordinary ash into strong masonry blocks. Earth blocks can be used to build houses, school, community buildings and other boundary walls, etc. "Fly Ash Brick Making Machine" is a unique manual automatic operated machine that harnesses Compressed Earth Block (CEB) Technology for economical, strong and durable earth construction. Houses made from these earth blocks (unfired bricks) are extremely long lasting. "Ash Brick Machine" is ideal for on-site production of bricks. Fly Ash bricks are made of fly ash, lime, gypsum, cement and sand. These can be extensively used in all building constructional activities similar to that of common burnt clay bricks. The fly ash bricks are comparatively lighter in weight and stronger than common clay bricks. Since fly ash is being accumulated as waste material in large quantity near thermal power plants and creating serious environmental pollution problems, its utilization as main raw material in the manufacture of bricks will not only create ample opportunities for its proper and useful disposal but also help in environmental pollution control to a greater extent in the surrounding areas of power plants. In view of superior quality and eco-friendly nature, and government support the demand for Fly Ash Bricks has picked up. Fly ash brick is products of basic cement clinker materials i.e. fly ash, stone, sand, lime, gypsum and cement. The mix is so ideally worked out to produce bricks of higher strength with consistency as well as uniformity. The manufacturing process is fully semi automatic with state of art technology. Though a new age product introduced in the market, Fly Ash bricks are very well accepted by the organized sectors in heavy industries, high rise buildings, large townships, colonies, etc. because of unique features and merits.

Key words— Selection of material, Material Composition and ratio, Chemical and physical Properties, Ash Brick, Ash Brick Machine, Design and Fabrication.

1 INTRODUCTION

In 1996, Parasite, at the New Mexico State University, conducted a laboratory study that involves using fly ash to stabilize and solidify hazardous radioactive waste materials.

They mixed the hazardous waste material with fly ash, and compacted the mixture into monoliths (solid cylindrical objects). The monoliths were then tested for their compressive strength, and were broken up for the TCLP (Toxicity Characteristic Leaching Procedure) test, which is a standard test procedure embraced by the U.S. Environmental Protection Agency. Their tests indicated that the type of fly ash used, the pH value of the waste, and the compaction pressure are important factors affecting the compact strength, and the TCLP test results. For instance, it was found that the optimum compaction condition for Class C fly ash was at compaction pressure of 675 psi (4.65 MPa) and pH of 9.2. The highest compaction pressure they used in making the monoliths was 3,000 psi (20.7 MPa). In 1995, Kobe and Plait in India compacted a mixture of fly ash, pond ash, lime and sand to make bricks. By using compaction pressure of 240 Kg/cm² (3,411 psi) and upon 6 hours of steam curing, the bricks were found to have a compressive strength of 140 Kg/cm² (1,989 psi), The bricks were judged to be unsatisfactory due to their high water absorption (13-22 %), high porosity and low abrasion resistance. Wolfe et al., at Ohio State University, explored the suitability of using a mixture of Class C fly ash and flue gas desulfurization (FGD) materials to produce a low permeability liner. They mixed the fly ash with the FGD materials (namely, the filter cake) and lime, and compacted the mixture sample by dropping 5.5 lb. hammer from a height of 1 ft (305 mm), as prescribed by ASTM D698. The study revealed that the compacted product, having a permeability coefficient in the neighborhood of 10⁻⁷ cm/s or 10⁻⁹ m/s, can be used as a low permeabil-

ity filter. The most important known previous study on compaction of fly ash is research conducted at the University of Missouri-Columbia. In 2001, Hu completed an M.S. thesis entitled "High-Pressure Compaction of Fly ash into Building Materials". In this study, Hu used both a high-grade fly ash and a low-grade fly ash obtained from the Thomas Hill Power Plant in Missouri to make cylindrical compacts or test samples, called "fly ash logs." Both the high-grade and the low-grade fly ash were derived from burning subbituminous coals mined in Wyoming. The main difference between these two types of fly ash is the amount of the unburned carbon in the fly ash i.e., loss on ignition (LOI). While the high-grade type, collected from pulverized-boiler units, had a LOI of less than 1%, the low-grade type, collected from cyclone-boiler units, had a LOI higher than 9%. The logs were produced by compacting fly ash mixed with a small amount of water, using a cylindrical mold and a cylindrical piston (rod), both of which made of stainless steel. Upon ejection from the mold, the "logs" had a uniform diameter of 48.7 mm, a length in the range 68 --78 mm, and a weight between 245 and 281 gm. Figure 1 shows a set of such logs compacted at the same pressure but different fly ash-to-water ratios (F/W ratios).

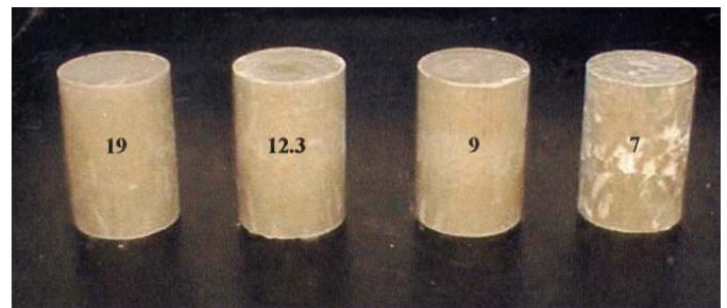

Figure 1: High-grad fly ash logs compacted at 5,000psi and different F/W ratio

Note- The number market on each log shows the F/W ratio

- Generally, the high-grade (low-LOI) fly ash produces much stronger compacts (logs) than the low-grade (high-LOI) fly ash.
- Usually, higher compaction pressures produce stronger logs. However, for the low-grade fly ash, compaction pressures higher than 5,000 psi result in cracks on logs and a decrease in strength.
- At compaction pressure of 5,000 psi, the optimum F/W ratio is 9.0 (i.e., 90 % fly ash and 10 % water) for the high-grade fly ash, and it is 5.87 (i.e., 85 % fly ash and 15% water) for the low-grade fly ash. Generally, increase in water content increases the strength and density of the logs until the foregoing limits were reached. Increase in the water content of the mixture also reduces the amount of water absorbed later during curing. More water means more hydration of lime. However, too much water in the mixture causes both a dilution of the hydrated lime and rapid setting, both of which are undesirable.
- Curing increases the strength of fly ash logs. An effective way to cure is simply placing the newly compacted logs in a moist-air environment for at least 24 hours. Then the logs can be immersed in water without damage, and with continued increase in strength over a long time.
- The density of the logs increases with increasing compaction pressure, and with increased curing time.
- Generally, the permeability (hydraulic conductivity) of the logs decreases with compaction pressure. For the high-grade fly ash logs, the permeability decreases to about 108 cm/s (10-10 m/s) at 16,000 psi compaction pressure, and or the low-grade fly ash the permeability decreases to about 108 cm./s (10b0 mis) when the compaction pressure is around 6,000 psi.

The compressive strength of the logs made of the high-grade fly ash having F/W ratio of 9 and compacted at 5,000 psi is approximately 34 MPa (4,900 psi) after 7 days of curing, and the strength increases with curing to 55 MPa (8,000 psi) and 76 MPa (11,000 psi) after respectively 28 days and 60 days of curing in water. Such strength matches that of high-strength concrete. Based on the above test results, Li and Lin, in 2002 [5], used the same two types of fly ash tested by Hu, and the same procedure to compact full-size fly ash bricks of 8-inch (203-mm) length, 4-inch (102-mm) width and 2.2-inch (56-mm) thickness – see Figure 2.

- Shivashesh Kaushik, Assistant Professor, Department of Mechanical Engineering in Amrapali Group of Institute, Haldwani Uttarakhand, India PH-9756298215. E-mail: shivashesh.rachit.kaushik@gmail.com
- Dr. Anirudh Gupta, Associate Professor, Department of Mechanical Engineering in Bipin Tripathi Kumaon Institute of Technology, Dwarahat, Almora, Uttarakhand, India PH-9412995855. E-mail: guptaanirudh87@gmail.com

The fly ash-to-water ratio used was 9 (i.e., 10% water based on the wet weight of logs) for the high-grade fly ash, and 5.67 (15% water based on the wet weight of logs) for the low-grade fly ash. Most of the bricks were compacted at 1,800 psi. Some bricks were compacted at different pressures ranging from 600 psi to 10,000 psi, to investigate the effect of compaction pressure on brick quality. Upon curing, each brick was tested of compressive strength, modulus of rupture, water absorption and freezing-thawing resistance. Note that ASTM standards require that half-bricks be used in some of these tests. The test results for bricks compacted at 1.800 psi are summarized in Table 1.

The properties of a typical commercial bricks and the corresponding ASTM requirements for the various types of bricks. Table 1 reveals the following facts:

- Even at the relatively low compaction pressure of 1,800 psi, upon 7 days of curing, both the high-grade-fly-ash and the low-grade-fly-ash bricks have compressive strengths higher than those called for by ASTM standards for clay and shale bricks (3,000 psi), and for Grades S-1 and S-2 of concrete bricks.
- Upon 28 days of curing, the high-grade-fly-ash bricks compacted at 1.800 psi gains a compressive strength exceeding that of a typical fired clay brick.
- The modulus of rupture (i.e., the flexural tensile stress that causes the brick to fail) of the fly ash bricks is much lower than that of ordinary fired clay bricks. However, for most applications, such as building bricks, this property is unimportant and hence not required by ASTM standards.
- The fly ash bricks tested for freezing-thawing failed after 7 to 9 cycles, whereas ASTM Standard C67 requires 50 cycles. This appears to be the biggest weakness of the fly ash bricks. However, this result should be kept in proper perspectives. First of all, in geographical regions that have warm climates, bricks will never freeze in winter time, and hence the freezing-thawing will never occur to or damage the fly ash bricks. Secondly. The fly ash bricks that were tested for freezing-thawing were compacted at 1.800 psi and cured for 28 days.
- The water absorption of the high-grade fly ash bricks is about 10%, which meets both ASTM Standard C55 for concrete building bricks, and ASTM Standard C62 for clay and shale bricks. The water absorption of the low-grade fly ash bricks is about 21 %, which exceeds both ASTM Standard C55 and 062.

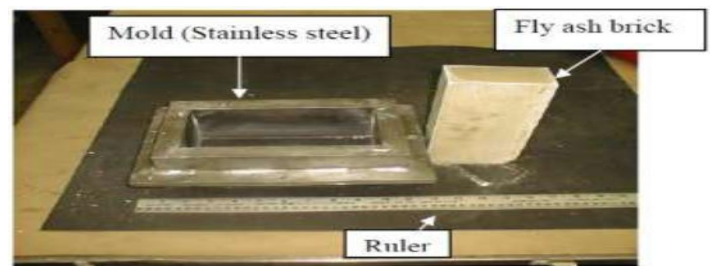

Figure 2: Compacted fly ash bricks and mold and dies

Table 1- Properties of fly ash brick compacted at 18,00psi and cured for different period as compared to properties of a regular commercial brick and ASTM standards.

Brick Type	Curing Time (days)	Compressive Strength (psi)	Modulus Of Rupture (psi)	5-hour Water Absorption (%)	24-hour Water Absorption (%)	Freezing-Thawing (cycles)
High-grade fly ash	7	4,680	342	12.6	12.8	--
"	28	7,850	350	10.6	10.7	7-9
"	60	8,641	354	9.8	10.0	--
"	90	9,330	441	10.9	11.2	--
Low-grade Fly ash	28	3,210	203	20.4	21.1	7-9
Regular fired clay brick	N/A	6,510	2030	0.30	0.55	>9
Concrete building bricks (ASTM Standard C55)	N/A	>3,000 for individual units under most severe conditions (Grades N-1 & N-2)	--	--	< 14 (15 lb of water in 105 lb of lightweight concrete)	--
Building bricks made of clay or shale (ASTM Standard C62)	N/A	>2,500 for individual units under most severe conditions (Grade SW)	--	<20 from 5 hours of boiling	--	--
Bricks (ASTM Standard C67)	N/A	--	--	--	--	> 50

2. PROBLEM STATEMENT

It is required to minimize the consumption of fertile land soil in manufacturing of building bricks and finds the alternative for this problem and also it is necessary to increase the utilization of fly ash in building brick so that we easily recycle the fly ash and protect our fertile land soil from sulphur which is present in fly ash otherwise land will be barren when waste fly ash spread all over the fertile land. To find the optimum material ratio composition of fly ash in building brick, this will satisfy the level of strength properties well, according to market demand and for specific situation like earth quack, after considering above valuable point it is necessary that to produce an effective, feasible and remarkable common solution for society which cover all the above point.

3. NEED OF PRESENT RESEARCH

It is necessary to improve the engineering properties such as strength, workability, plasticity, water absorption tightness and Efflorescence of building bricks etc, which directly improves all the mechanical properties such as compressive strength, tensile strength, bending, flexural strength etc, to estimate the stability and durability of the brick. It is also require maintaining the optimum Indian standard uniform size and shape of fly ash bricks and to reduce the plastering thickness and which will also helpful in reduction of the overall manufacturing cost of high strengthens building brick.

After reviewing all above valuable point it is necessary that to produce an effective, feasible common solution for society and constructional industries which cover all the above point, and that will only achievable by keeping all above points in mind while developing a specific concept

and design for making varying shapes of fly ash bricks through special purpose manual semi automatic fly ash brick machine by using lever mechanism, which will helpful to manufacture wide range of fly ash bricks with cheap production cost, high production rate, easily accessible and easily handle by unskilled labour, easily transportable, eco friendly technology, eco friendly to environment and satisfy all needs of industries and society.

4. OBJECTIVE

The objective of this project is "Develop the non-polluting ash brick making machine". This objective involves the following specific objectives:-

- To provide and develop a specific concept for making varying shapes of fly ash bricks such as rectangular shape fly ash bricks and ohm shape fly ash bricks through special purpose manual semi automatic fly ash brick machine by using lever mechanism.
- Studying the engineering properties of fly ash.
- Fly ash brick machine research project has been designed to manufacture wide range of fly ash bricks with cheap production cost, high production rate, easily accessible and easily handle by unskilled labour, easily transportable, Eco friendly technology and eco friendly to environment.
- Pollution Control:-The technology adopted for making fly ash bricks is eco-friendly. It does not require steaming or auto calving as the bricks are cured by water only. Since the firing process is avoided, there are no emissions and no effluent is discharged. On the other hand, it solves the problem of fly ash disposal.
- Energy Conservation:-General precautions for saving electricity are required to be followed by the unit by adopting energy conservation techniques not only to conserve the power but also to save considerable expenditure in their own and also in the interest of the nation as a whole.

5. MATERIAL PROPERTIES AND DIE DETAILS

5.1. PHYSICAL PROPERTIES

Fly ash consists of fine, powdery particles that are predominantly spherical in shape, either solid or hollow, and mostly glassy (amorphous) in nature. The carbonaceous material in fly ash is composed of angular particles. The particle size distribution of most bituminous coal fly ashes is generally similar to that of silt (less than a 0.075 mm or No. 200 sieve). Although sub bituminous coal fly ashes are also silt-sized, they are generally slightly coarser than bituminous coal fly ashes. The particle size distribution of raw fly ash is very often fluctuating constantly, due to changing performance of the coal mills and the boiler performance. The specific gravity of fly ash usually ranges from 2.1 to 3.0, while its specific surface area (measured by the Blaine air permeability method) may range from 170 to 1000 m²/kg. The color of fly ash can vary from tan to gray to black, depending on the amount of unburned carbon in the ash. The lighter the color, the lower the carbon content Lignite or sub bituminous fly ashes are usually light tan to buff in color, indicating relatively low amounts of carbon as

well as the presence of some lime or calcium. Bituminous fly ashes are usually some shade of gray with the lighter shades of gray generally indicating a higher quality of ash.

Table 2: Contents present in ash

CONTENTS	LIGNITE FLY ASH (%)	COAL FLY ASH (%)
L.O.I	1.0 TO 2.0	3-15
SiO ₂	45.59	40-64
Al ₂ O ₃	23-23	15-29
Fe ₂ O ₃	06-4.0	2-11
CaO	5.0-16.0	0.1-1.0
MgO	1.5-0.5	0.2-4.0
SO ₃	0.5-0	0.-1.7

5.2. CHEMICAL PROPERTIES

It may be seen that lignite fly ash is characterized primarily by the presence of silica, alumina, calcium etc. Presence of silica in fine form makes it excellent pozzolanic material. Its abundant availability at practically nil cost gives a very good opportunity for the construction agencies.



(a) Isometric view RBD



(b) Side view of RBD



(c) Isometric view ohm shape brick die

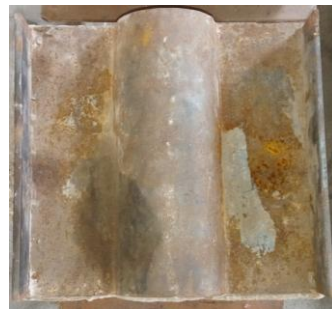

(d) Top view of ohm shape brick die



(c) Rectangular shape brick



(d) Ohm shape brick



(e) Mold

Figure 3: Different Photographic View of fly ash bricks and mold and dies

Table 3: Chemical properties of ash

Silica	35-59 %
Alumina	23-33%
Calcium Oxide	10-16%
Loss on ignition	1-2%
Sulphur	0.5- 1.5%
Iron	0.5- 2.0 %

5.3. EXPERIMENTAL RESEARCH PROJECT DESIGN DETAILS

5.3.1 CAM DESIGN

In order to design the cam profiles for a radial cam, first of all the displacement diagram is necessary and then the profile of the cam. Known variable: Cam lift=70mm, Dwell for the next=150°, during the next 60° of cam rotation, the follower returns to its original position with simple harmonic motion, Dwell during the remaining= 60°

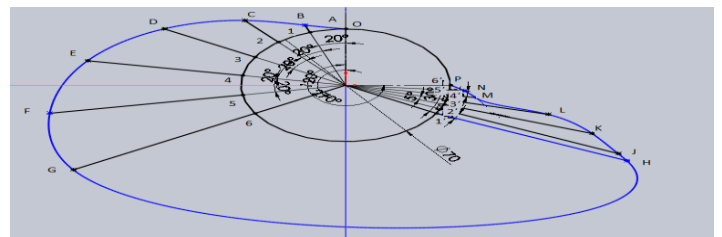

Figure 4: Cam profile.

5.3.1.1 DISPLACEMENT DIAGRAM

- Draw horizontal line AX=360°. On this line, mark AS=120° to represent out of stroke; SR=150° to represent dwell; RP=30° to represent return stroke and PX=180° to represent dwell. Draw the vertical line=70mm to represent the cam lift or stroke of the follower and complete the rectangle.

- Divide the angular displacement during out stroke and return stroke into any equal number of even parts (6) and draw vertical lines through each point.
- Since the follower moves with simple harmonic motion, therefore draw a semicircle with AY as diameter and divide into six equal parts.
- From points a, b, c....etc. draw horizontal lines intersecting the vertical lines drawn through 1, 2, 3...etc. and 0', 1', 2'...etc. at B, C, D...M, N, P.
- Join the points A, B, C....etc. with a smooth curve. This is the required displacement diagram.
-

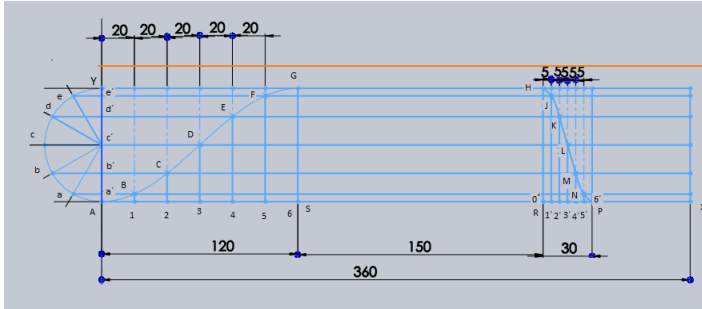

Figure 5: Displacement diagram

5.3.2. EXPERIMENTAL SET UP DIAGRAMS



Figure 6: Front View of Fully Fabricated Fly Ash Brick Machine.

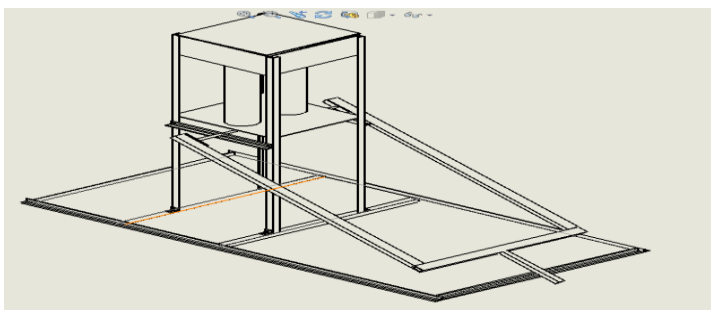

Figure 7: Isometric design view of ASH Brick Machine.



Figure 8: Side View of Fully Fabricated Fly Ash Brick Machine.

5.3.3. PROCEDURE FOR CONSTRUCTION CAM PROFILE

Draw a base circle with radius equal to the minimum radius of the cam=70mm with center O. From OA, mark angle AOS=120° to represent outstroke, angle SOR=150° to represent dwell and angle ROP=30° to represent return stroke. Divide the angular displacement during outstroke and return stroke into the same number of equal even parts as in displacement diagram. Join the points 1, 2, 3...etc. and 0', 1', 2'.....etc. with center O and produce beyond the base circle. Now set off 1B, 2C, 3D....etc. and 0'H, 1'J...etc. from the displacement diagram. Join the points A, B, C...L, M, and P with a smooth curve. The curve AGHPA is the complete profile of the cam.

(Cam based mechanism for uplifting ram were varying dies were placed present inside the mold cavity for providing required pressure regarding production of bricks mention as an optional and additional concept only theory and its discription is mention here, practically single slider crank mechanism concept with lever mechanism was introduced for actual practice in practical experimental setup of fly ash brick machine)

6. METHEDODOLOGY

The fly ash brick maker machine has a simple four-stage operation:

STAGE 1: FILLING AND LOCKING THE MOULD

- Disengage the lever and completely open the mould lid.
- Place the rectangular mould plates on the ram head.
- Move the yoke and the lever to rest on the side opposite to the locking lever. The ram will descend.
- Fill prepared soil into the scoop and fill the mould. Take care that the mould is filled to the top and lever the surface.
- Close the mould lid with an impact using the lever handle provided for the purpose.

STAGE 2: COMPACTION

Move (throw) the lever and yoke to the compaction side

- a. On the compaction side, 'press' the lever till it rests on the ejection pivots. The ram moves up by 70 mm in this operation.

STAGE 3: EJECTION

- a. Move the lever and the yoke by about 25 cm about the horizontal lever.
- b. Release the locking lever and open the mould lid.
- c. Move the lever below the horizontal plane till the entire block and part of ram plate comes out of mould and then hold it there.
- d. Remove the block carefully from the ram plate.
- e. Place the blocks carefully on the wooden tray.
- f. Move the lever and the yoke to the initial filling position.

STAGE 4: STACKING

Place the block in the stocking yard; Than the bricks are placed on wooden pallets and kept as it is for two days thereafter transported to open area where they are water cured for 10 -15 days. The bricks are sorted and tested before dispatch.

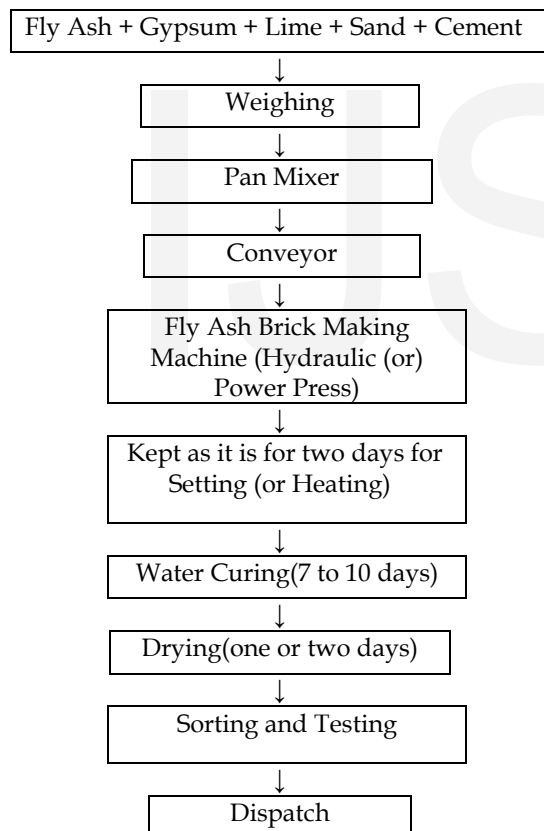

Figure 9: Process Flow Chart

7. CONCLUSION

Our ultimate goal in this engineering without borders challenge is to improve the standard of living of the people in the coastal area. Above all, we aim to achieve this in a sustainable way; that is culturally approved, technically feasible and economically reasonable. Chiefly, we have chosen to attack the human development areas of poverty and housing, for two

main reasons. First, these problems undermine the fundamental human rights of villagers to relative wealth and shelter in their lives, and second, we see these as the first liberating steps to greater humanitarian development. Our aim is to implement a locally run brick making industry in village that will produce at least 500 bricks per day, with the overarching goal of empowering the community economically. The village will then have the potential to sell the bricks for extra income, or to use them in future community building projects. Our project will include the preliminary plans for future business, as well as construction projects. We aim to encourage and foster both of these possibilities through the initial organization of the brick business and dialogue on the opportunity for future building development, especially within the sector of housing improvement. Thus, we firmly believe in the capacity of our project to increase community income and to empower the community to be more self-reliant in future humanitarian development.

8. FUTURE SCOPE

Present paper show theoretically with practical manual fabrication solution to constructional society based on effective design approach, which is achieved by developing a specific concept for making varying shapes of fly ash bricks through special purpose manual semi automatic fly ash brick machine by using lever mechanism. In the next part of this project based research paper brief focus on numerical approach of design specification of machine, force calculation of varying manual load, hydraulic force and pneumatic force required for manufacturing fly ash bricks for varying percentage composition of fly ash bricks material regarding require amount of production then analyze and acknowledge the above effects on production cost, high production rate will be mention with description of new design modification for enhancement of effectiveness and efficiency of this machine. The future modification based on following points which are as follows.

- Use hydraulic system for better compression.
- Use solar heating system for fast production.
- Design a conveyor for to install between pan mixer and machine

REFERENCES

- [1] Department Of Forests, Ecology & Environment, Government Of Karnataka
- [2] Henning O., Lach V. 1983, Chemie ve stavebnictví, SNITL Praha
- [3] Semerák P., Cerný R. 1997. A Capacitance Method for Measuring the Moisture Content of Building Materials. Stavební obzor 6: 102-103 (in Czech).
- [4] Bhuvaneshwari S, Robinson R. G. Gandhi S.R, "Stabilization of expansive soils using fly ash", Fly ash India, 2003, New Delhi.
- [5] AIS Group, 2011, AIS Group, Australia, viewed 2 September 2011, <http://www.ais-group.com.au/homeinsulation/products/granulated.php>
- [6] Alibaba International, 2011, Shengya Shandong Machinery Co., China, viewed 21 September 2011, http://syshengya.en.alibaba.com/product/355763201-210461490/QMR2_45_Manual_Block_Machine.html
- [7] Current Steel Rates/Prices, 2011, All India Steel Rollers Association, New Delhi, viewed 9 September 2011, <www.allindiasteelra.com/current_prices>